

<https://www.kakuhunter.com/en/>



Teams, Zoom, Skype, Team Viewer...  
On-line demo and meeting are available!



(Manufacturer)

**Shashin Kagaku Co., Ltd.**  
Product Company

7-2-10, Nojihigashi, Kusatsu City, Shiga, 525-0058, Japan  
TEL. +81-77-566-1208 FAX. +81-77-565-3506



Kindly browse to our website for the latest information,  
inquiry and brochure about Kakuhunter

<https://www.kakuhunter.com/en/>

E-mail: [kakuhunter@kakuhunter.com](mailto:kakuhunter@kakuhunter.com)

(Sales Distributor)

Innovative and Advanced Planetary Mixer  
with degassing function

# *Kakuhunter*



# Planetary mixer with degassing function can generated process for various materials.

The Revolution-Rotation Motion Mixer & Degassing System "Kakuhunter" evolves following recent needs, besides, we also have been leading the market over supplying products with numerous variation.

From now on, we will keep creating new value with our individual technology.



Innovative and Advanced Planetary Mixer  
with degassing function

## **Kakuhunter** Development history

Since 90's, we have been required high accuracy degassing in case of bubble which mixed in when accurate and downsized electronic material was proceeded mixing.

We have started development of industrial planetary motion mixer with excellent versatility and durability, which is possible to do accurate mixing and degassing simultaneously in following with customer needs. On 1992, high quality mixing and degassing machine equipped with individual revolution and rotation control system (SNB series, which called now "Kakuhunter") was released newly.

At the stage of development, it was very tough what to do about circumgyration ratio of revolution and rotation.

Initially, we have developed machine with 2motor type, after this development, we have started development with single motor which has variable circumgyration ratio, then existing machine was born with wide circumgyration ratio range of revolution and rotation.

From that moment onward, large machine with high throughput as well as machine equipped with vacuum equipment which enhanced degassing effect. Then, eventually we also have developed small size machine following the market demand.

We try to keep forwarding new value on research and development over and over.



Innovative and Advanced  
Planetary Mixer  
with degassing function

***Kakuhunter***

achieve optimization

# Revolution

Crushing

Degassing

Rotation

Separating

Dispersion

Emulsification

1992

Primary products  
SNB Series



250N



SK-2000



SK-300TVS



SK-300S



SK-4000T

**Currently**



# Field, Purpose, Material

Applicable to motion mixing and degassing of various kinds of materials for wide range of uses across a variety of industrial fields.

Information equipment including mobile devices and tablet PCs essential to our life as well as automobiles and home information appliances which realize a comfortable life are supported by many high performance electronic components. Essentials in manufacturing these electronic components are expensive electronic materials, magnetic materials and functional materials such as rare metals.

Advanced energy materials are also essential to photovoltaic generation, secondary cells and fuel cells, which is focusing attention across range of industries.

Medical supplies and cosmetics essential to health and beauty are also supported by various high-value added materials.



## Possible to do by Kakuhunter

### ◆ Principal capability of Kakuhunter

**Mixing** Material: Alumina Powder + Silicon Resin



**Degassing** Material: High Viscosity Adhesive



**Dispersion** Material: Fluorescent Powder + Resin



**Crushing** Material: Adhesive + Color Stone (Zirconium ball used)

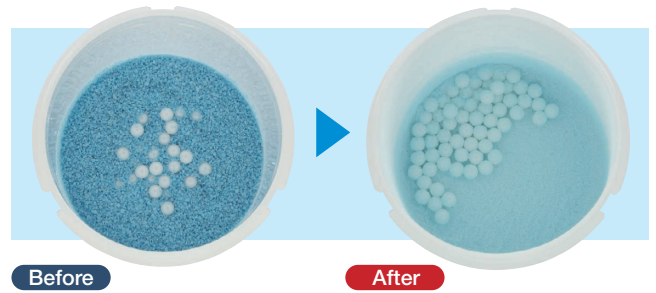

**Kneading** Material: Clay



**Separation** Material: Adhesive + Color Stone



**Emulsification** Material: Egg + Oil + Vinegar

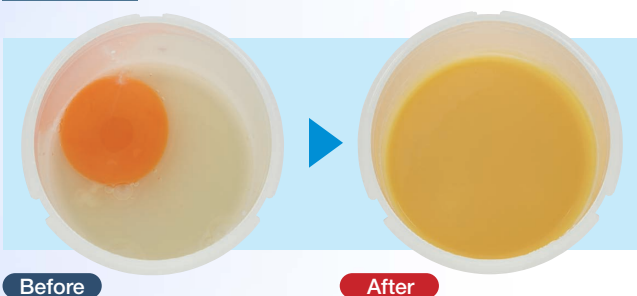

# Disadvantage of Other Method Mixing

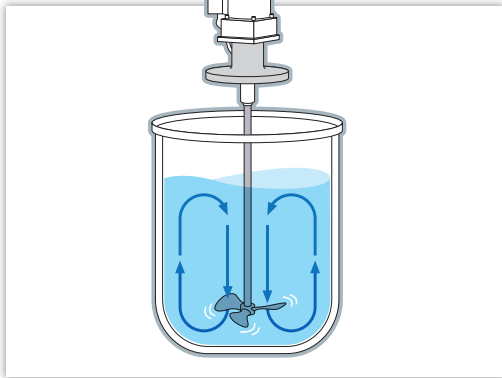

## Propeller Type

### Feature and Disadvantage

- It takes time to mix.
- Propeller part contacts the material, thus causing loss of material.
- Propeller shears composition, thus causing damage of material.
- Accurate mixing is unable.
- Need to clean up.
- Degassing is unable.

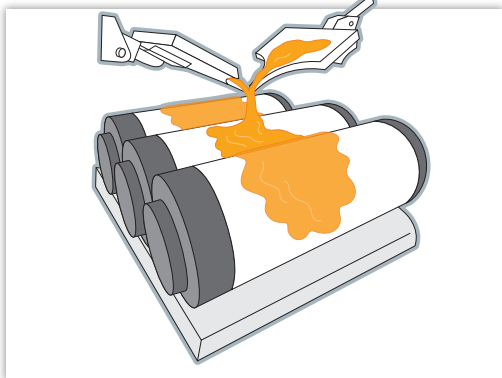

## The Three Roll Type

### Feature and Disadvantage

- It takes time to mix.
- Roll part contacts the material, thus causing loss of material.
- It is unsuitable for low viscosity material.
- Need to clean up.
- It can be dangerous for getting involved with roller.

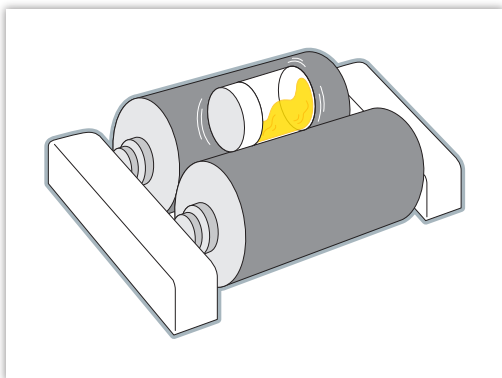

## The Roller Type

### Feature and Disadvantage

- It takes time to mix.
- Air bubbles may be generated at the time of mixing, and separation or sedimentation may occur due to materials made ahead of time.
- It is unsuitable for high viscosity material.

## ▶ Comparison with other mixing method

Method	Revolution-Rotation Type (Kakuhunter)	Propeller Type	The Three Roll Type	Roller Type
Mixing Time	◎ Short time	○ Relatively short time	△ Long time	△ Long time
Processing Quantity	△ Depending on container capacity	◎ Possible to manage large quantity	△ Possible to manage continuous operation	◎ Possible to manage large quantity
Material Viscosity	◎ Low-High viscosity level	○ Low-Middle viscosity level	○ Middle-High viscosity level	○ Low-Middle viscosity level
Degassing	◎ Centrifugal degassing + Vacuuming	× Not possible	△ Can be effective	× Not possible
Foreign Substances Interfusion	◎ Container	△ Propeller/ Container	△ Roll	◎ Container
Labor hour in case of replacing material	◎ No need to clean up	× No need to clean up propeller and tank	× No need to roll part	◎ No need to clean up
Heat Generation	△ Has heat	△ Has heat	△ Has heat	○ Has less heat

◎ : Excellent ○ : Good △ : Similar level × : Not good



# Disadvantage of Other Method **Degassing**

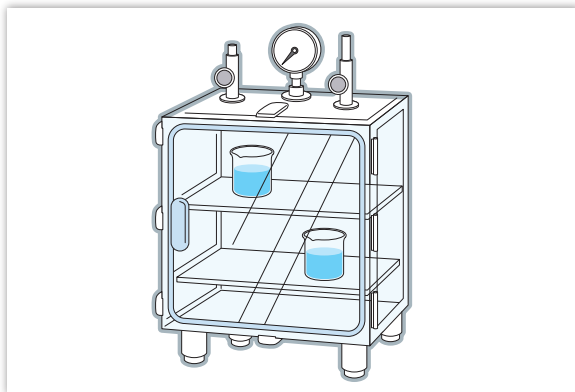

## Vacuum Degassing Machine

### Feature and Disadvantage

- Unable to mix.
- Fluid level is raising so that it can be spilled out.
- It takes time to mix on high viscosity material and would be hard to degas on bottom part.
- It takes time to degas, therefore operating efficiency is not good.
- It vaporized, then eventually decreased quantity.
- Composition can be changed depending on material.

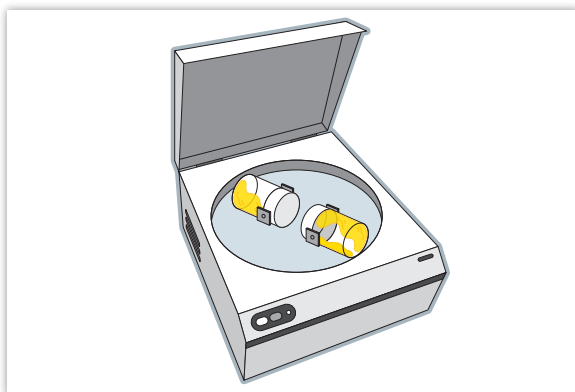

## Centrifugal Separator

### Feature and Disadvantage

- Unable to mix.
- In case of material with difference of specific gravity, it split out.
- In case of high viscosity material, it remain slight bubble.
- Processing quantity is small.

## We effectively solve problem for mixing and degassing on other methods.



Kakuhunter is capable to accommodate mixing and degassing for various material regardless of any viscosity.

Machine as well as container is operating into enclosed space, therefore no need for interfusion of foreign substances, it can operates continuous job over replacing materials. Shearing and defoaming action for film thickness foaming function which creates under revolution-rotation combination, it is possible to do accurate mixing and degassing simultaneously with short time.



Depending on setting function of combination of revolution and rotation speed, it can be flexible for variable motion setting in accordance with material feature or kinds, then it can achieve appropriate mixing and degassing short time.

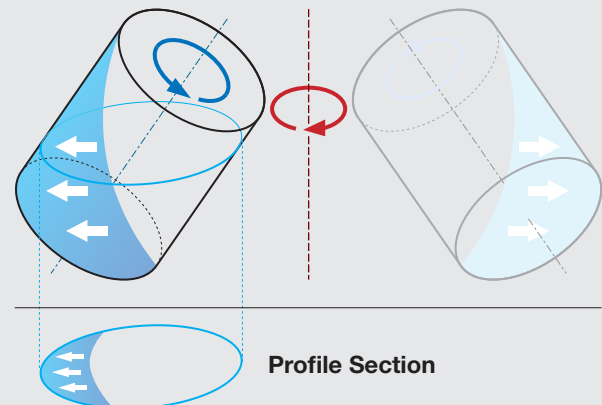

With centrifugal force by revolution move, material was grinding sidewall of container, then it can create mixing function with shearing force between container sidewall and material by rotation move.

Field, Purpose, Material  
Disadvantage of Other Method  
Advanced Technology  
Standard Model  
Specific Model  
Vacuum Equipped Model  
Mass Production Model  
Exclusive Model Filling Machine  
Various Container Adapter  
Specification View  
Introduction Example Academic-Industrial Alliance Research and Development

# Advanced Technology

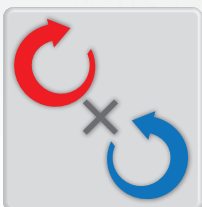

## Revolution-Rotation Individual Control System [P.09 →](#)

Due to ratio change setup function of revolution speed and rotation speed, it is capable to operate with appropriate mixing and degassing in accordance with material feature for short time.



## Fixed ratio for revolution-rotation [P.09 →](#)

Rotation follows with fixed ratio of revolution.

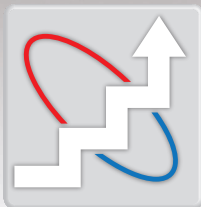

### Step Mode [P.11 →](#)

Enable to correspond for various demands of mixing and degassing by continuous driving with several different operational patterns.

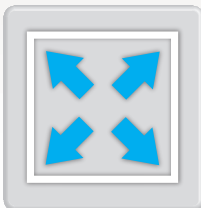

### Vacuum Reduced Pressure Function [P.12 →](#)

The vacuum reduced pressure function enables removal of ultrafine bubbles.

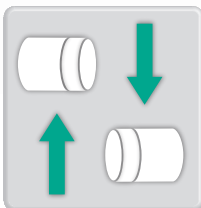

### Container Tray Shift [P.19 →](#)

Mixing force enhanced by shifting the container tray for the rotation axis and increasing the contact area between the container and the material.

Field, Purpose, Material
Disadvantage of Other Method
<b>Advanced Technology</b>
Standard Model
Specific Model
Vacuum Equipped Model
Mass Production Model
Exclusive Model Filling Machine
Various Container Adapter
Specification View
Introduction Example Academic-Industrial Alliance Research and Development





# Revolution-Rotation Individual Control System

## Revolution-Rotation Individual Control System

Setup for the revolution 9 step variable and rotation 10 step variable is carried out and the total number of possible setups reaches 90 by combining both actions (except for some products). As 90 user defined channels (Except for some products) and 10 fixed data channels can be set as memory channels (recorded recipe for operation), this contributes to operational efficiency across a wide range of scenes from research and development to mass production basis.

The individual setup of revolution and rotation speed allows for minimizing thermal elevation., then it enables to mix and degas preventing material from changing.

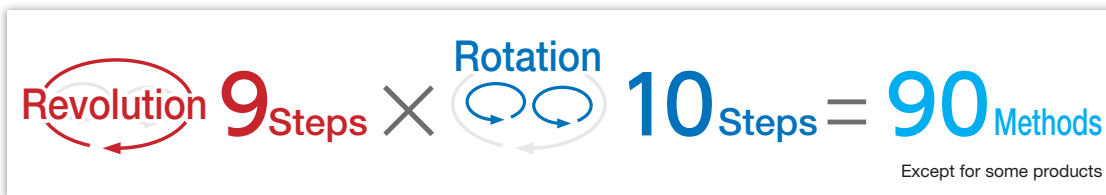

		Low <span style="color: red;">→</span> revolution setting <span style="color: red;">→</span> High									
		1	2	3	4	5	6	7	8	9	
rotation setting	Low	0	1-0	2-0	3-0	4-0	5-0	6-0	7-0	8-0	9-0
	1	1-1	2-1	3-1	4-1	5-1	6-1	7-1	8-1	9-1	
	2	1-2	2-2	3-2	4-2	5-2	6-2	7-2	8-2	9-2	
	3	1-3	2-3	3-3	4-3	5-3	6-3	7-3	8-3	9-3	
	4	1-4	2-4	3-4	4-4	5-4	6-4	7-4	8-4	9-4	
	5	1-5	2-5	3-5	4-5	5-5	6-5	7-5	8-5	9-5	
	6	1-6	2-6	3-6	4-6	5-6	6-6	7-6	8-6	9-6	
	7	1-7	2-7	3-7	4-7	5-7	6-7	7-7	8-7	9-7	
	8	1-8	2-8	3-8	4-8	5-8	6-8	7-8	8-8	9-8	
	High	9	1-9	2-9	3-9	4-9	5-9	6-9	7-9	8-9	9-9

Example of fixed ratio of rotation speed

Example of our standard model speed range

(Note.1) Some machine has limitation of speed ratio.



## Fixed ratio for revolution-rotation

### Fixed ratio for revolution-rotation

Rotation follows with fixed ratio of revolution.  
This is adopted in SK-300SII for small single cup.

## Mix high-viscosity materials in a short time.

This system generates strong gravity acceleration by centrifugal force of revolutions to mix high viscosity materials in a short time.

### Application Reference

Mixing and degassing of high-viscosity printing ink.  
(Example of mixing by SK-350T II)

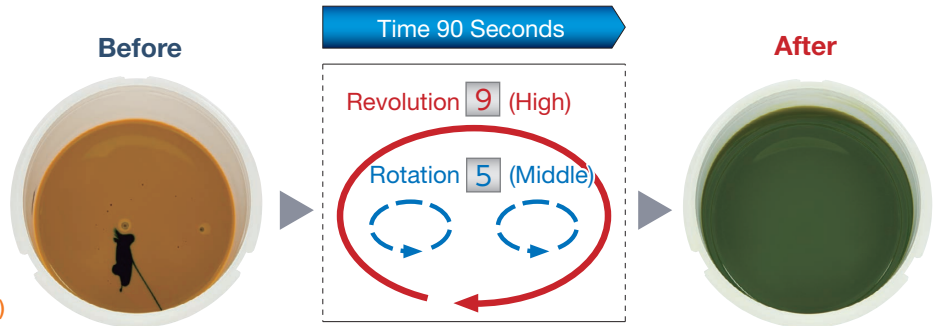

## Carry out degassing without using a vacuum pump due to the nature of the material.

This system generates strong gravity acceleration by centrifugal force of revolutions to degas materials in a short time.

### Application Reference

Degassing of silicon resin.  
(Example of mixing by SK-350T II)

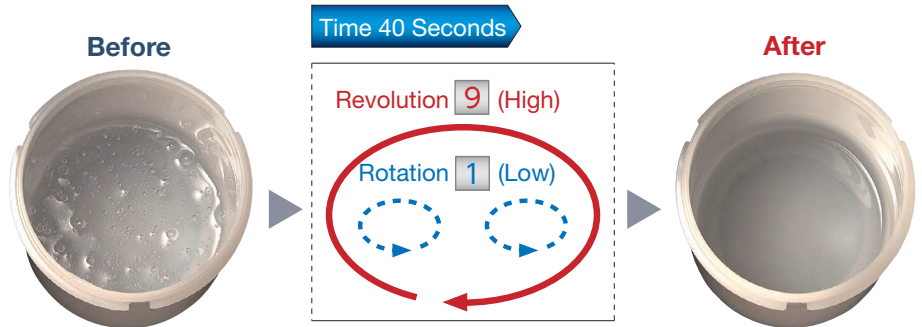

## Prevent a change in the nature of the material due to a thermal elevation of the material.

**With revolution-rotation individual control system, it prevents material from thermal elevation.**

For motion mixing of high viscosity material, it is necessary to increase the revolution speed, and the temperature of the material rises significantly due to friction can be affected due to this temperature rise depending on materials.

However, the individual setup function of revolution and rotation speed can prevent a thermal elevation and carry out motion mixing and degassing.

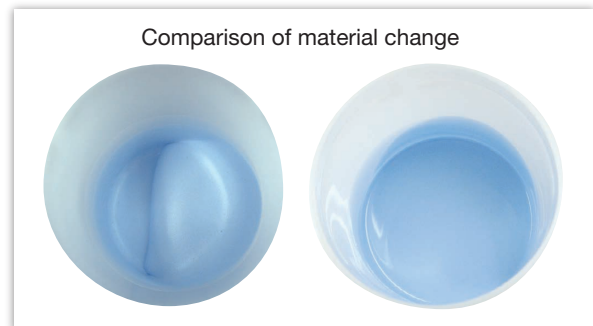



# Step Mode

## Step Mode

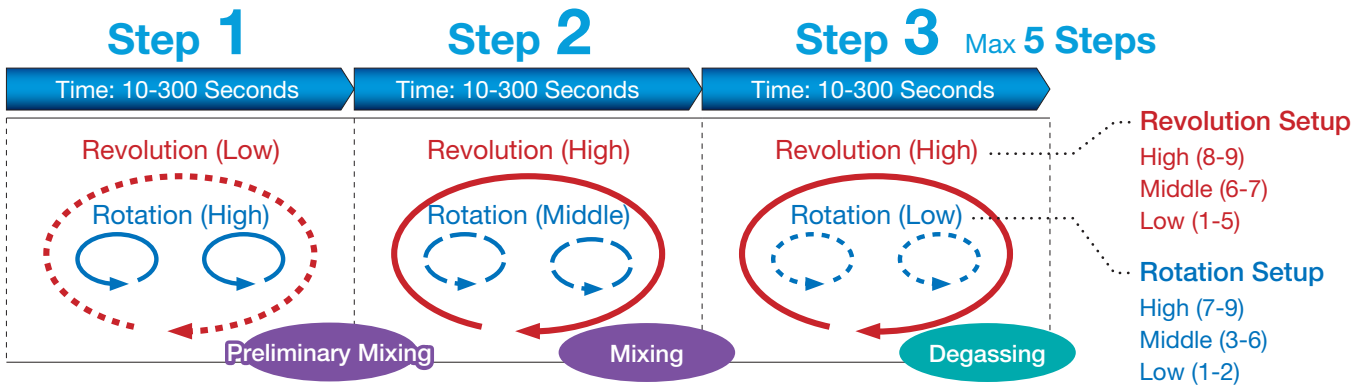

Some different movement patterns are achieved by using the step mode. Continuous driving responds to a wide variety of motion mixing and degassing needs.

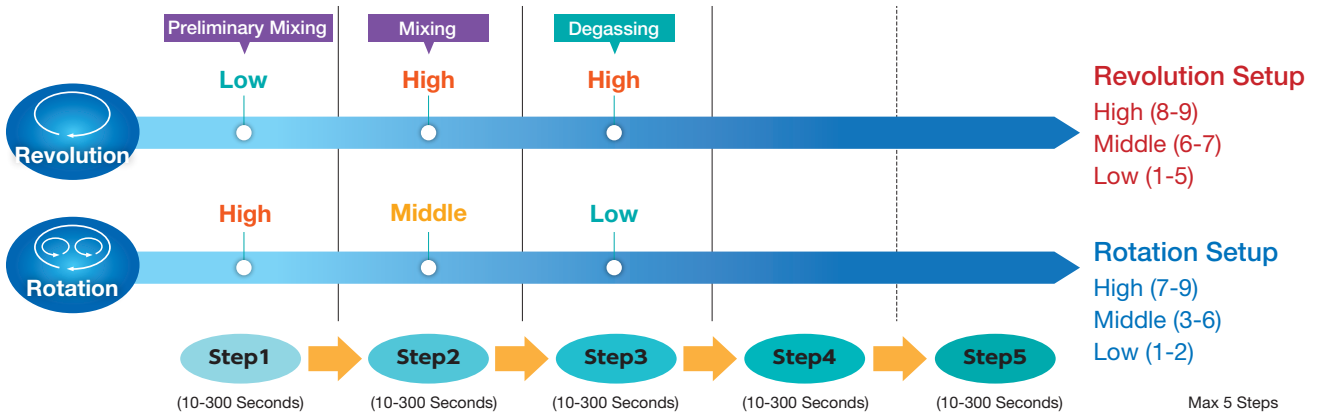

### Eliminates lumps of material in mixing

Mixing force is increased by individual revolution and rotation control and step mode to eliminate lumps.

In mixing powder and resin, powders are easily formed into lumps and difficult to crush. The individual setup function for revolution and rotation speed can be used to prevent lumping for motion mixing and degassing.

#### Application Reference

Pasting of Alumina and silicon resin  
 (Example of mixing by SK-350TII)

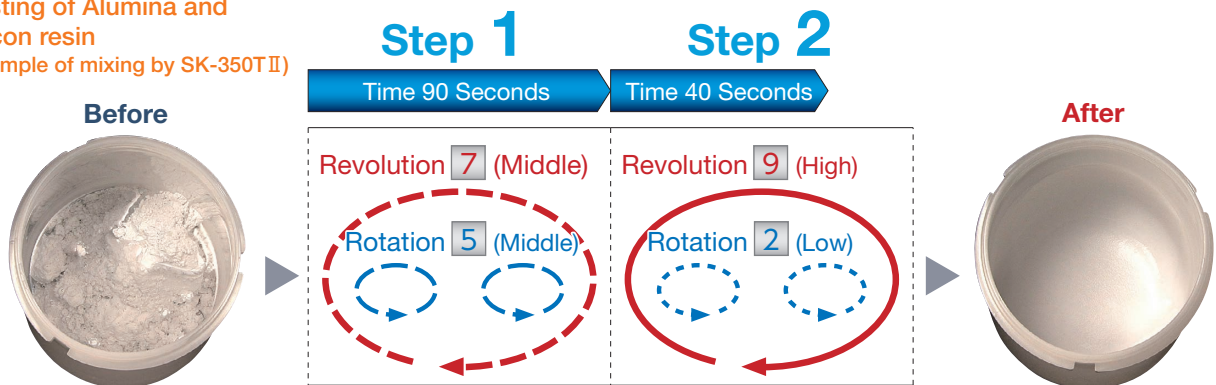





# Vacuum reduced pressure function

## Vacuum reduced pressure function

It enables to do voluntary setup of vacuum level over monitoring vacuum reduced pressure level, therefore enables removal of ultrafine bubbles.

It can be expected to bring about effects of enhancement in conductivity and insulation capability required for electronic materials, reduction in defect rates of products due to bubbles in optical materials and prevention of blank short of a syringe due to air bubbles.



Only at the time of vacuum reduced pressure mode, the vacuum chamber is shut off and only the rotor section is depressurized.

The vacuum chamber method facilitates setup of a container, and can be used as a desiccator. In addition, a long container is also easily mounted.



It enables to do voluntary setup of vacuum level over monitoring vacuum reduced pressure level.

## Mixing, Dispersion of the material with difference in specific gravity.

With individual revolution and rotation controls and additional step mode, mixing force is increased! In addition, with a vacuum reduced pressure function, even fine bubbles are removed.

With the individual setup function of revolution and rotation, and with step mode, degassing can be carried out after sedimentation is controlled by bringing in line the speed of revolution while maintaining the rotation speed necessary for motion mixing and dispersion. In addition, the degassing effect is enhanced by vacuum reduced pressure.

### Application Reference

Motion mixing and dispersion of fluorescent powder and silicon resin with a difference in specific gravity. (Example of mixing by SK-300TVS-A)

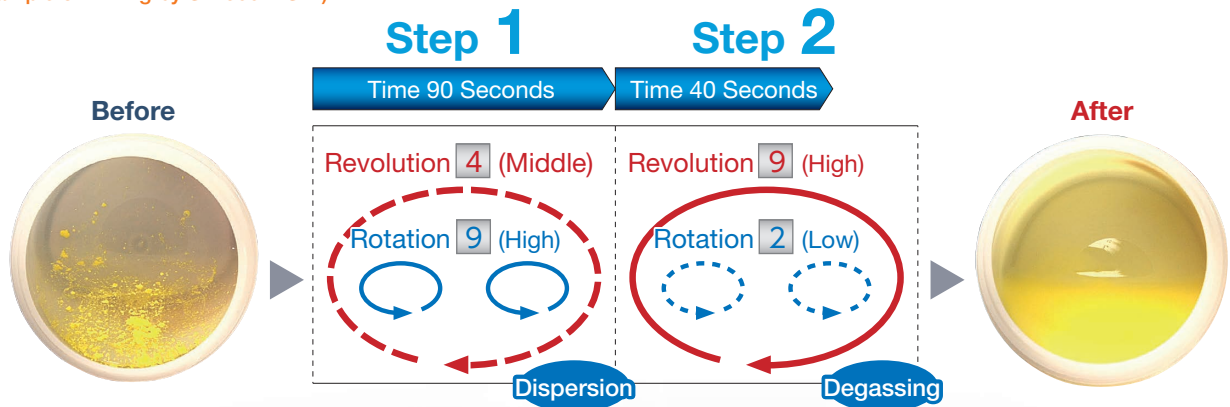

# All Product Range Introduction

## Standard Model

## Specific Model



**SK-300SII**

Cup Capacity  
**300ml × 1 Cup**



**SK-350TII**

Cup Capacity  
**400ml × 2 Cup**



**SK-400TR**

Cup Capacity  
**400ml × 2 Cup**



**SK-1100T**

Cup Capacity  
**1100ml × 2 Cup**



Throughput

**300g**

**1 kg**

## Vacuum Equipped Model



**SK-300TVS-A**

Cup Capacity  
**300ml × 2 Cup**

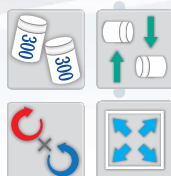

**SK-350TV/TVS**

Cup Capacity  
**400ml × 2 Cup**



**SK-1100TVIII**

**SK-1100TVSIII**

Cup Capacity  
**1100ml × 2 Cup**

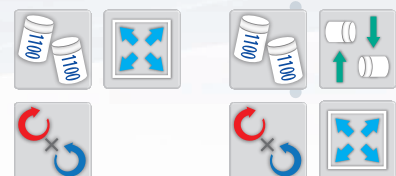



### SK-2000T

Cup Capacity  
2000ml × 2Cup



2kg



### SK-3000TII

Cup Capacity  
2000ml × 2Cup



3kg

## Mass Production Model



### SK-4000T/TV

Cup Capacity  
4000ml × 2Cup



5kg

10kg

### Standard Model

Standard type equipped with individual revolution-rotation control system. (Except some machine model)

### Vacuum Equipped Model

It enables removal of ultrafine bubbles due to vacuum reduced pressure function. Besides, it can be expected to bring about effects of enhancement in conductivity and insulation capability required for electronic materials, reduction in defect rates of products due to bubbles in optical materials and prevention of blank short of a syringe due to air bubbles.

### Mass Production Model

4L, 7L container or specific container are available, which is mass production model.

### Specific Model

To keep rotation direction is as usual, new function which revolving direction is changeable either clockwise or anti-clockwise for revolution. Under vacuum pressure, it may change material property, however it enables to achieve high precision degassing even atmospheric pressure condition.



### SK-10000T/TV

Cup Capacity  
7000ml × 2Cup



# Standard Model

Motion planetary mixer with mixing and degassing system **SK-300SII**



It upgraded functions into high-functional entry model.

**Medium Mode** It could sustain revolving temperature.

**Wave Mode** It could enhance mixing and dispersing force.



## ● Mode setting according to the purpose of use

SK-300SII added Medium mode to existing mode (Mixing mode/ degassing mode). Easy operation keeps as before and could manage more variety of materials and applications following your preferred mode setting.



## ● Included balance navigation function

Easy balance adjustment can be done by a balance error detection and a navigation function.



## ● SK-300SII exclusive functions

### ■ Medium Mode

Due to lower speed ratio of rotation compared with Mixing mode, it enables to sustain revolving temperature and also manage heat sensitive materials.

### ■ Wave Mode

Due to up and down speed of revolution and rotation move, it enables to enhance mixing and dispersing force effectively.

## ● One simple feature of 1 cup

SK-300SII with one simple feature of 1 cup has the same specification as our bigger range product lines, which setting time is maximum 30min(Total 9steps) and it has 10 setting channels.

## ● 300ml container /Maximum 310g

300ml container /Maximum 310g (Gross weight ) are available. Even the compact machine, the process can be done with mentioned specification.

## ● Fulfilling safety design

Upper lid lock function during operation , an operation stop when the upper lid opened and malfunction preventing function is available, which is considered safety design. Additionally, the balance error detection, motor malfunction, maintenance warning and notification function can assure to use the product safely.





## Selectable specific mode up to materials add to standard operation

<p><b>L-mode</b></p> <p>Anti-aggregation function</p> <p>Mixing power and liquid, then avoid to occur lump condition.</p>	<p><b>T-mode</b></p> <p>High Dispersion function</p> <p>Sustain lump and separation, then enhance dispersion.</p>	<p><b>P-mode</b></p> <p>Rotation waving move function</p> <p>Rotation speed creates up and down like wave, which enhances mixing force.</p>	<p><b>D-mode</b></p> <p>Weak revolution move function</p> <p>Due to slight move of revolution, which enables to eliminate micro fine bubbles.</p>	<p><b>F-mode</b></p> <p>Ant-separation function</p> <p>Sustain separation for materials with different specific gravity.</p>	<p><b>HS-mode</b></p> <p>Degas priority function</p> <p>High speed mode with degas priority</p>
---	---	---	---	--	---

### Motion planetary mixer with mixing and degassing system **SK-350TII**

With variable ratio of revolution-rotation, 90 motion patterns are achieved. This sophisticated model can be performed at research and development as well as small production level.



#### ● Advanced function with individual revolution-rotation control system basic type

It enables to mix and degas for maximum 700g material with dual cup type (max 350g) into 400ml container. Then, we increased basic function with advanced specification, which added to dispersion prevention mode in order to control material dispersion in case of powder material and liquid which has difference of specific gravity, as well as high speed mode.

\*Maximum weight can be different from material property. In terms of weight, it includes container and adapter.



<p><b>F-mode</b></p> <p>Ant-separation function</p>	<p><b>HS-mode</b></p> <p>Degas priority function</p>
---	--

SK-350TII Operating Panel



### Motion planetary mixer with mixing and degassing system **SK-1100T**

- Maximum throughput is 1100ml, 1100g gross weight. It enables to install 180ml cartridge with adapter.
- Machine model with high revolution and wide radius gyration for high quality materials revolving rotation speed control system enhanced liquid and powder mixing, then control lumps occurrence.



<p><b>T-mode</b></p> <p>High Dispersion function</p>	<p><b>F-mode</b></p> <p>Ant-separation function</p>
--	---



Field, Purpose, Material  
Disadvantage of Other Method  
Advanced Technology  
Standard Model  
Specific Model  
Vacuum Equipped Model  
Mass Production Model  
Exclusive Model Filling Machine  
Various Container Adapter  
Specification View  
Introduction Example Academic-Industrial Alliance Research and Development

# Standard Model

## Motion planetary mixer with mixing and degassing system **SK-2000T**



- Maximum throughput 2kg x 2 Cup
- Custom made mixing machine which correspond to customer's designated container.
- Maximum container size: Diameter 150mm, Height 170mm
- It enables to be equipped with several containers (while adapter is combined) and it contributes material loss due to right choice of container in following with production level.
- It enables to have certain throughput without adapter.



### L-mode

Anti-aggregation function

### P-mode

Rotation waving move function

### D-mode

Weak revolution move function



## Motion planetary mixer with mixing and degassing system **SK-3000TII**



Due to dual cup system of max 3kg each available, total 6 kg high of specific gravity material can be performed. Due to wide radius gyration, it enables to have centrifugal force under low rotation and then control composition change on thermal elevation of materials.

### T-mode

High Dispersion function

### F-mode

Ant-separation function



# Specific Model

Motion planetary mixer with mixing and degassing system **SK-400TR**



**New Technology (Changeable rotation function) equipped model!**  
**Mixing force 1.5 times, Degassing Force 1.4 times evolution!**

**New Release Machine!**

● **Changeable Rotation Function!** **NEW**

To keep rotation direction is as usual, new function which revolving direction is changeable either clockwise or anti-clockwise for revolution. Under vacuum pressure, it may change material property, however it enables to achieve high precision degassing even atmospheric pressure condition.

● **Drastically increased revolving speed of rotation!**

To keep centrifugal force of revolution, it enables to achieve setting which revolving speed pf rotation can be surpassed to revolving speed of revolution.

Mixing force is drastically enhanced, thus it can correspond to various materials case.



**Acceleration / Deceleration-mode**

Acceleration and deceleration control system for rotation motion

**Wave-mode**

Rotation only, max 1,200 rpm

**Continuous-mode**

Continuous operation mode between step

**Drastically enhanced mixing and degassing force with new technology!**

**It enables to achieve mix and degas for short time even high viscous materials.**

To increase max rotation speed, it increased about three times wider setting area than existing models.

Due to wider setting area, mixing force enhanced 1.5 times and degassing force enhanced 1.4 times more.

In this way, SK-400TR enables to achieve to mix and degas for difficult materials which is struggling to mix with existing machine.

**Easy operation by LCD touch panel!**

Applied LCD touch panel on control panel, thus it enables to perform easy operation with detailed information display.

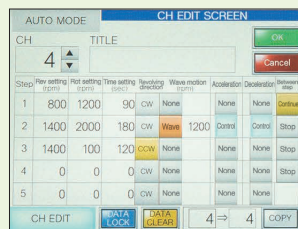

**Possible to use with temperature Monitor. (Optional equipment)**

Non-contact temperature sensor enables to monitor actual temperature move during operation through PC software as an optional equipment.

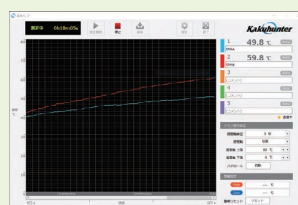
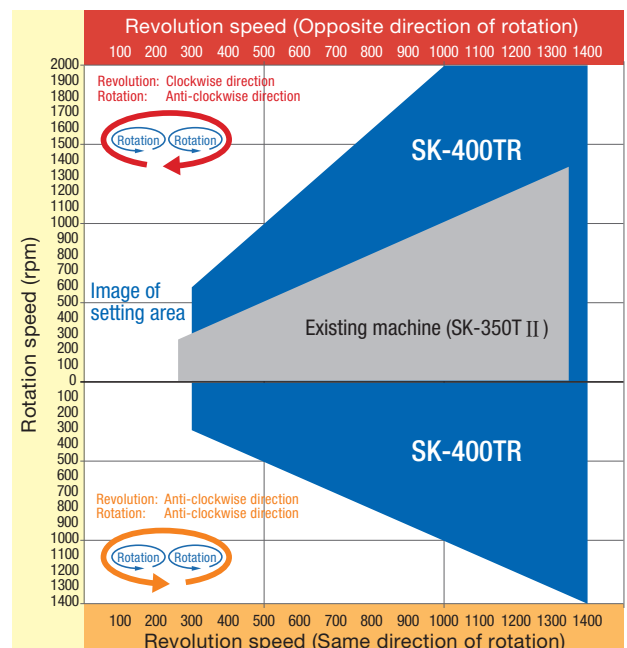

Image is showed through specific software.



Field, Purpose, Material  
 Disadvantage of Other Method  
 Advanced Technology  
 Standard Model  
 Specific Model  
 Vacuum Equipped Model  
 Mass Production Model  
 Exclusive Model Filling Machine  
 Various Container Adapter  
 Specification View  
 Introduction Example Academic-Industrial Alliance Research and Development

# Vacuum Equipped Model

## Vacuum Control Function

Three machine model in common

SK-300TVS-A SK-1100TVⅢ/TVSⅢ  
SK-350TV/TVS

### On Delay

- Due to delay of entering moment of vacuum, then controls thermal elevation and composition change of materials.
- Controlling dispersion of fine powder when fine powder is mixing with liquid, it can also avoid short of dispersion, mixing and sticking fine powder to the container lid.



### Off Delay

- Due to delay of disappearing moment of vacuum, it extends degassing time till the rotation stops and can enhance degassing accuracy.

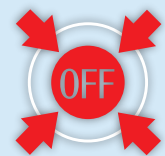

## Container Tray Shift

Two machine model in common

SK-300TVS-A SK-1100TVⅢ/TVSⅢ  
SK-350TV/TVS

- Applying container tray shift on the rotation axis, mixing capability enhanced!



Shifting container tray, compared with standard machine (straight type), contact of between container and material increased, then mixing force enhanced.

Besides, long type container can be equipped, which sustains distance from central axis of revolution and centrifugal force occurs entirely, then enables to do effective mixing.





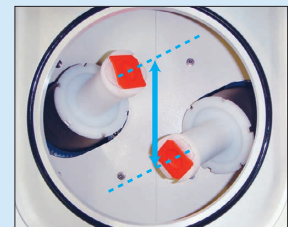

Reference of equipped standard container

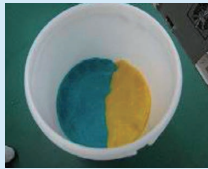

Reference of equipped 55cc syringe adapter

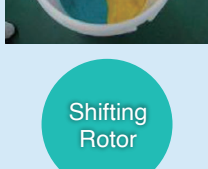
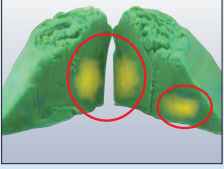
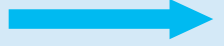
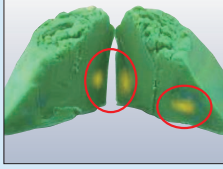
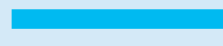
- Comparison of mixing time. (Straight rotor VS Shifting Rotor)

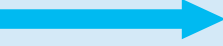
	120 seconds later	210 seconds later	240 seconds later
   	 Mixing incomplete 	 Mixing incomplete 	 Mixing complete 
	<p>Compared with straight rotor, shifting rotor can cut down mixing time about 50%.</p> <p>(*Attention) Material: Wheat clay    Mixing setup: 9-5</p>		



## Planetary Centrifugal Mixer With Vacuum Device Machine SK-300TVS-A

### Vacuum equipped type

High capability vacuum reduced pressure function model. Due to individual revolution-rotation control system and container tray shift system, it can achieve enhancement of mixing and effective degassing. (capacity 300ml/310g gross weight x 2cups)

#### ● Enhancement of degassing with vacuum machine!

It enables removal of ultra-fine bubbles due to vacuum reduced pressure function. Besides, it can be expected to bring about effects of enhancement in conductivity and insulation capability required for electronic materials, reduction in defect rates of products due to bubbles in optical materials and prevention of blank short of a syringe due to air bubbles.

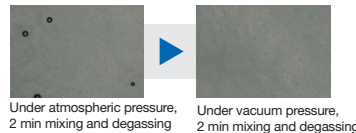

Microscope pic.  
\* Results might be changed depend on conditions.



## Motion planetary mixer with mixing and degassing system SK-350TV/TVS

### Vacuum equipped type

Greatly improved mixing performance with the same features as existing models! A new advanced function model equipped with the individual revolution and rotation speed control system!! (capacity 400ml/350g gross weight x 2cups)

#### ● Individual revolution and rotation speed control system

The ratio of revolution and rotation can be adjusted, and 90 different speed combination patterns can be set.

#### ● Optimum settings

It enabled to set detailed setting for materials property and kinds, then achieve mixing and degassing for various kind of materials.

#### ● Sustains thermal elevation

To adjust rotation speed, without changing materials property, it enables to sustain thermal elevation due to individual speed control system of revolution and rotation.

**F-mode**  
Ant-separation function



Exclusively for SK-350TVS



## Motion planetary mixer with mixing and degassing system SK-1100TVⅢ/TVSⅢ

### **New Release Machine!** Vacuum equipped type

Vacuum reduced pressure function model for medium scale production. Due to individual revolution-rotation control system and wide radius gyration, it enables to occur centrifugal force even low revolving speed, also control thermal elevation and composition change. (capacity 1,100ml/1kg gross weight x 2cups)

#### ● Container tray is available **straight type** and **shifting type** and they can be used depending on purpose.

Straight type has high performance in terms of high throughput, on the contrary, shifting type has high performance in terms of mixing capability because tilting type is increasing contact between container and materials.

\*Effect will be changed depending on materials. It can be chose preferable type depending on purpose of amount of throughput or mixing power.

#### Acceleration / Deceleration-mode

Acceleration and deceleration control system for rotation motion

#### Wave-mode

Rotation only, max 1,200 rpm

#### Continuous-mode

Continuous operation mode between step

#### Throughput Priority

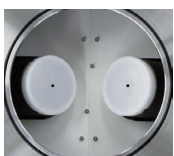

Straight Container Tray

SK-350TV and SK-1100TVⅢ



In case of throughput priority, **straight container type** would be preferable and **shifting container** is for mixing priority. **It enables to choose either tray type.**

#### Mixing Priority



Shifting Container Tray

SK-350TVS and SK-1100TVSⅢ



Exclusively for SK-1100TVSⅢ



# Mass Production Model

## Non vacuum or vacuum equipped type selectable **SK-4000T/TV**

### Vacuum or non vacuum type selectable

- We newly released mass production model 10kg for non vacuum or vacuum type up to customer's requirement.
- : Revolution/Rotation individually speed can be controlled. (Rotation: 0-1.0 times speed changeable)
- : Max 10kg gross weight (5kg x 2) throughput mass production model.
- : Customize model which 4000ml standard container as well as specific container can be correspond.

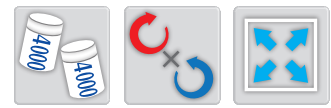

### Wave-mode

Rotation only, max 1,200 rpm

### Continuous-mode

Continuous operation mode between step

### Acceleration / Deceleration-mode

Acceleration and deceleration control system for rotation motion

## Non vacuum or vacuum equipped type selectable **SK-10000T/TV**

### Vacuum or non vacuum type selectable

- We newly released mass production model 20kg models for non vacuum or vacuum type up to customer's requirement.
- : Revolution/Rotation individually speed can be controlled. (Rotation: 0-1.0 times speed changeable)
- : Max 20kg gross weight (10kg x 2) throughput mass production model.
- : Customize model which 7000ml standard container as well as specific container can be correspond.

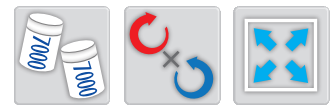

### Wave-mode

Rotation only, max 1,200 rpm

### Continuous-mode

Continuous operation mode between step

### Acceleration / Deceleration-mode

Acceleration and deceleration control system for rotation motion

## Drastically enhanced Productivity!

### 1. Easy operation on touch panel!

- Settable CH is max 100CH.
- It enables to change CH name depends on usage.
- Password lock function for setting.

### 2. Vacuum machine feature

- Selectable non vacuum or vacuum type
- Enables to select each vacuum level per cup tray individually.
- Customize model for specific container
- Adjustable each revolution and rotation speed (0 - 1.0 times)
- Enhanced mixing and degassing force with individual revolution and rotation speed control system equipped machine.

## Specifications

	SK-4000T	SK-4000TV	SK-10000T	SK-10000TV
Type	Standard type	Vacuum equipped type	Standard type	Vacuum equipped type
Container	4000ml HDPE container or SUS container		7000ml HDPE container or SUS container	
Max capacity	5kg(Including container) x 2 cups		10kg(Including container) x 2 cups	
Revolution speed	120 - 600 rpm, 9 levels		100 - 400 rpm, 9 levels	
Rotation speed	0 -1.0 times against Rev speed, 10 levels		0 -1.0 times against Rev speed, 10 levels	
Setup time	10 -300 sec (10 decimal sec)		10 -300 sec (10 decimal sec)	
Step mode	1- 5 Step		1- 5 Step	
Memory channel	Fixed CH: 10CH User settable CH: 90CH		Fixed CH: 10CH User settable CH: 90CH	
Power source	Three phase 200 -240V, 50/60Hz		Three phase 200 -240V, 50/60Hz	
Electric consumption	Max 15KVA		Max 20KVA	
Outer dimension	W1330xD1010xH1120mm	W1330xD1010xH1120mm (Vacuum pump excluded)	W1900xD1300xH980mm	W1900xD1300xH980mm (Vacuum pump excluded)
Weight	About 700kg	About 730kg	About 1500kg	About 1530kg

\* It differs machine throughput depending on materials characteristic.

\* Revolving speed may change depending on materials characteristic.

\* Detailed specification may change without prior notice.

# Exclusive Model

## Microplate motion planetary mixer with mixing and degassing system SK-MP12T



It can handle uniform mixing of microplate sample and removal of micro bubble with high speed. It contributes to reliability of inspection result.

- Various microplate can be equipped, also it enables to uniform mixing for short time and removal of micro bubble simultaneously.
- Due to use of exclusive adapter, 18, 96 well size, in addition, 384, 1536 well size can be mixing and degassing.
- Due to optional adapter, it can perform mixing and degassing for micro tube or cultivation tube.

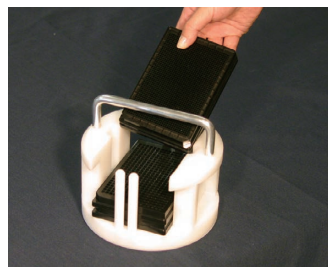

### Test result for 1536 well micro tube

Before mixing  
1536

It dispensed two color of aqueous pigment into 1536 well microplate for HTS (High Throughput Screening).

Existing plate mixer or centrifuge plate is unable to mix on above case.

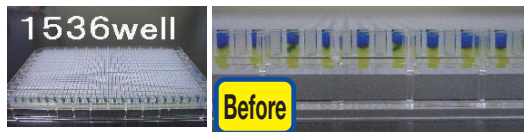

After mixing  
1536

Using SK-MP12 mixing machine, it enables to mix viscosity pigment, as well as normal assay can mix completely.

Besides, mixing and degassing for enzyme, substrate solution, reagent screening, as well as it would confirm effect for cell dissolution and mixing of reporter gene assay with cultivated cell or mixing of micro beads slurry by using SK-MP12.



### Test result for micro tube

Before

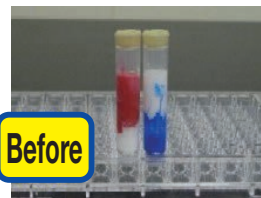

Before mixing  
96 well micro tube

After weighing each HTS compound into 96 well micro tube, it adjust under some concentration, preserve it, then makes library compound.

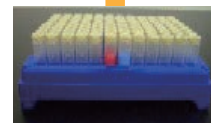

96 well micro tube

After



After mixing  
96 well micro tube

Not only high density microplate, but deep plate or 96 well micro tube enables to mix certainly for short time.

# Exclusive Model

## Centrifugal Planetary Mixer for Long Cartridge SK-BS12T

We newly released specific model for long cartridge which enables to equip with 6oz (180ml) and 12oz (360ml) cartridge.

- Due to individual control system of revolution and rotation speed, it enables to achieve uniform mixing for short time and remove micro fine bubbles.
- Due to selection of cartridge (6oz (180ml), 12oz (360ml)) in following with production level, it enables to enhance productivity and workability.

\* In case of use of 6oz cartridge, it requires specific adapter.



### ▶ Operational procedure

Procedure 1



Set long cartridge into cup tray

Procedure 2



Close top lid after confirming long cartridge installed.

Procedure 3



Press START ON for control panel. Mixing and degassing jobs will complete for few minutes.

## It enables to solve various problem under dispensing process!

- ▶ It enables to enhance dispensing accuracy due to efficient degassing bubbles inside of cartridge.

### Are you facing any problems below?

- ✔ We would like to mix with different specific gravity materials.
- ✔ We would like to degas bubbles which generated when shifting from container to container.
- ✔ Remaining bubbles inside of cartridge unable to dispense evenly.
- ✔ We would like to avoid loss of material or break of material composition due to direct contacts of propeller or three roll mills.



Kakuhunter can correspond and solve for various problems.



# Filling Machine

In Shashin Kagaku, we have various range of filling machine for customer's material or depending on process.

## Kakuhunter using process

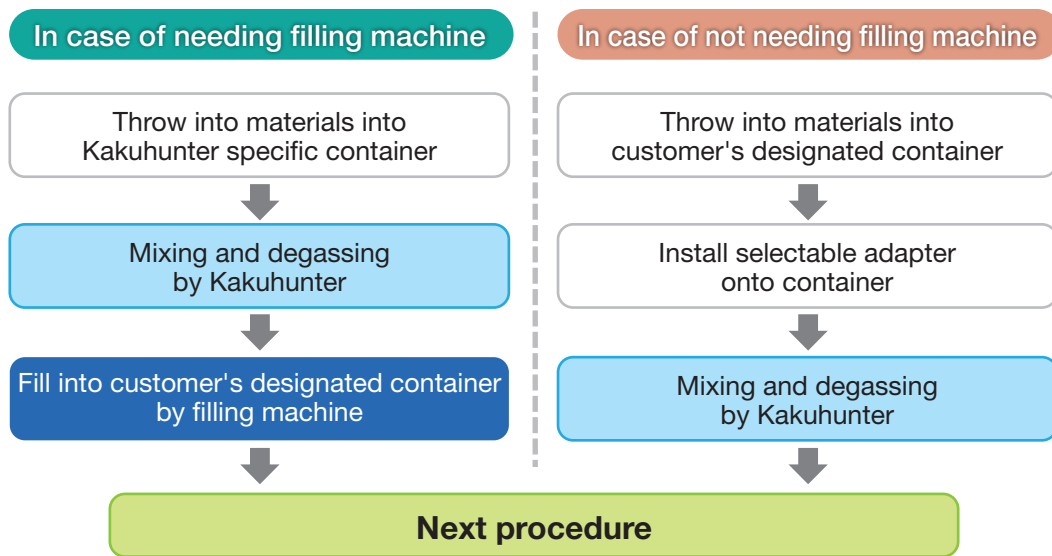

## Pressurization

- It put material container into pressurization tank, then materials would be filling by air pressure with valve switching.
- Filling is suitable for low viscosity materials.
- Price is relatively cheap.

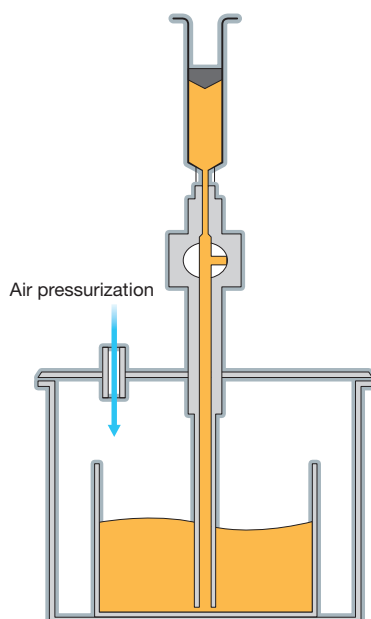

## Table Hoisting System

- Fixed material container onto table which controlled accurately, then filled directly to syringe through container adapter.
- It enables to fill effectively due to short and straight passing way for materials.
- Du to non valve use, composition of wetted part is very simple and it enables to fill no loss of materials.
- Filling loaded is max 3MPa, therefore it is suitable for filling materials such as high viscosity or high thixotropy.

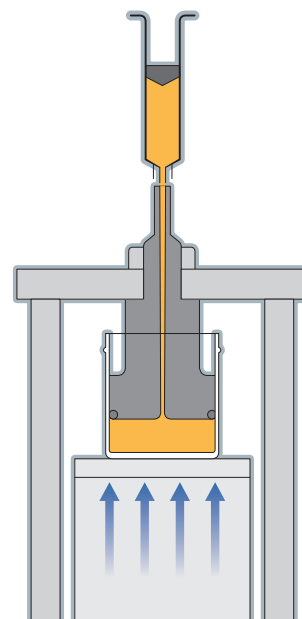

# Various type of adapters

## ◆ Various type of adapters

We have variety of range of adapters for disposable cup, stainless container, paper container, syringe, cartridge, glass bottle and centrifugal pipe.



With an adapter matching for syringe, it enables to re-disperse loaded syringe filled with chemical material or electronic material such as LED material.

Besides, it is possible to use much longer syringe type for cup tray shift of SK-300TVS-A and SK-1100TVSⅢ.



In case of SK-2000T, we would manufacture cup tray which can be suitable for customer's designated container, however that would be within one cup (maximum  $\varphi$  150mm $\times$ 170mm) per 2Kg capacity.

Existing cup can be available and no need to purchase new container for it.

Besides, for all our product, it would be possible to install by using adapter (optional goods) for customer's designated container or syringe. (Some of container shape is unable to manufacture)

**Cold adapter enables to sustain thermal elevation caused mixing.  
We have wide variety purpose of adapters.**



## ◆ Adapter products range for compatible containers.

● : Container with adapter ○ : Standard Container without adapter

Kinds	Quantity (ml)	Maximum insert number	Compatible models																	
			SK-300SII	SK-300TVS-A	SK-350TII SK-350TV SK-350TVS SK-400TR	SK-1100TVIII SK-1100TVSIII	SK-2000T	SK-3000TII	SK-4000T/TV	SK-10000T/TV	SK-MP12T	SK-BS12T								
PE container  Other size: from 5ml onward available (5ml, 6ml, 12ml, 24ml, 35ml, 58ml)	60	1~2	●	●	●															
	110	1~2	●	●	●															
	125	1~2	●	●	●															
	150	1~2	●	●	●															
	190	1~2	●	●	●															
	250	1~2	●	●	●															
	300(No:002)	1~2	○	○	●															
	400(No:006)	1~2			○	●	●	●												
	500	1~2				●	●	●												
	610	1~2				●	●	●												
	650	1~2				●	●	●			●	●								
	750	1~2				●	●	●			●	●								
	1100(No:007)	1~2						○	●	●	●	●								
	2000	1~2							●	●	●	●								
4000	1~2										○	●								
7000	1~2											○								
Syringe/ cartridge type	3	5	●																	
	5	5	●																	
	10	4	●																	
	20/30	1	●																	
	3	5×2		●	●															
	5	5×2		●	●															
	10	4×2		●	●															
	20/30	1×2		●	●															
	10	3×2			●															
	20/30	1×2			●															
	10	3×2			●															
	50/55	1×2		●	●															
	5	1~20×2					●	●	●											
	10	1~20×2					●	●	●											
	30	1~7×2					●	●	●											
	50/55	1~7×2					●	●	●			●*2	●*2							
100/180	1~4×2					●*	●*	●*			●*2	●*2	●							
180/360	1×2										●*2	●*2	●							
Disposable Cup	100	1~2	●	●	●															
	150	1~2	○	●	●															
	200	1~2	●	●	●															
	300	1~2			●*3	●	●	●												
	500	1~2				●	●	●			●	●								
	1000	1~2				●	●	●			●	●								
	2000	1~2				●	●	●			●	●								
Disposable cup for cold adapter	100	1~2	●	●*4	●*4															
	150	1~2			●*4															
Micro Plate (18, 96 well also possible)	384well																			●
	1536well																			●

: We also have exclusive machine such as cartridge type of 6oz(180ml), 12oz(360ml) and micro plate compatible type.

: Contact us in case of requiring for other container or adapter.

: Above descriptions may change without notice.

\* : It can fit with syringe one pc each cup tray.





\*2: SK-4000T/TV and SK-10000T/TV available container, cup, adapter, please contact with us separately!

\*3: It enables to fit this disposable cup, but there is no lid. Therefore it must take care of materials quantity.

\*4: It can install cold adapter, but vacuum type model may not be guaranteed sustaining thermal elevation as same level as non vacuum type model.







Also, using cold adapter under vacuum pressure, icel gel of cold adapter may cause leakage risk.

# Specification View

Model Item	Standard Model				
	SK-300SII	SK-350TII	SK-1100T	SK-2000T	SK-3000TII
Machine appearance					
Insert Page	P.15	P.16	P.16	P.17	P.17
Standard container	300ml × 1cup Less than 30ml various syringe type available	400ml × 2cup Less than 55ml various syringe type available	1100ml × 2cup Less than 100ml various syringe type available Less than 180ml various cartridge type available	User designated (Max about 2000ml x 2 cup)	2000ml × 2cup
Maximum Capacity	310g	350g x 2 cups	1kg x 2 cups	2kg x 2 cups	3kg x 2 cups
Other container	Depends on adapters, it enables to use various kind of container or syringe.				
Number of revolution	Mixer mode : 200-2000rpm Medium mode : 200-2000rpm Degassing mode : 400-2200rpm *	9 Stage setup	9 Stage setup	9 Stage setup	9 Stage setup
Number of rotation	Mixer mode: follows at 40% of revolutions Medium mode: follows at 20% of revolutions Degassing mode: follows at 3% of revolutions *	10 Stage setup	10 Stage setup	10 Stage setup	10 Stage setup
Setup time	Maximum 30 minutes (9 step total)	Maximum 25 minutes (5 step total)	Maximum 990 seconds (5 Step total)	Maximum 25 minutes (5 Step total, 1 step max is 900 seconds)	Maximum 25 minutes (5 step total)
Step Mode	9 Step 9 different kinds of motion pattern It can do continuous operation (on condition setup)	5 Step 5 different kinds of motion pattern It can do continuous operation (on condition setup)	5 Step 5 different kinds of motion pattern It can do continuous operation (on condition setup)	5 Step 5 different kinds of motion pattern It can do continuous operation (on condition setup)	5 Step 5 different kinds of motion pattern It can do continuous operation (on condition setup)
Memory (Condition memory function)					
User Setup Channel	7 CH	90 CH	90 CH	90 CH	90 CH
Fixed Data Channel	3 CH	10 CH	10 CH	10 CH	10 CH
Power supply	Single Phase AC100-120VAC±10% Single Phase AC200-240VAC±10% 50/60Hz	Single Phase AC100-120VAC±10% Single Phase AC200-240VAC±10% 50/60Hz	Single Phase AC200-240VAC±10% 50/60Hz	Three phase AC200-240VAC±10% Three phase AC385-415VAC±10% 50/60Hz	Three phase AC200-240VAC±10% 50/60Hz
Power consumption	1.38kW	1.38kW	2.0kW	2.5kW	3.0kW
Outer dimension	W340×D315×H370 (mm)	W400×D482×H495 (mm)	W565×D597×H741 (mm)	W646×D663×H851 (mm)	W726×D743×H860 (mm)
Weight	About 24kg	About 50kg	About 140kg	About 225kg	About 265kg

\* •Medium mode/Wave mode are exclusively for SK-300SII.  
 •In case of wave mode, revolution speed would differ up and down based on setting speed, with this reason, rotation speed follows up and down, too like wave.  
 •Wave mode has revolving speed limitation ( Revolution: 1,000-1,790 rpm/ Rotation: about 400-716rpm)



Specific Model	Vacuum Equipped Model			Exclusive Model	
SK-400TR	SK-300TVS-A	SK-350TV SK-350TVS	SK-1100TVⅢ SK-1100TVSⅢ	SK-MP12T	SK-BS12T
					
P.18	P.20	P.20	P.20	P.22	P.23
400ml × 2cup Less than 55ml various syringe type available.	300ml × 2cup Less than 55ml various syringe type available.	400ml × 2cup Less than 55ml various syringe type available	1100ml × 2cup Less than 100ml various syringe type available Less than 180ml various cartridge type available	6 plates x 2 (10pcs for 384 well)	12oz, 6oz Long cartridge x 2pcs
350g x 2 cups	310g x 2 cups	350g x 2 cups	1kg x 2 cups	2kg x 2 cups	
Depends on adapters, it enables to use various kind of container or syringe.	Depends on adapters, it enables to use various kind of container or syringe.			Depending on adapters, it enables to use various container or syringe.	
300-1400rpm	9 Stage setup	9 Stage setup	9 Stage setup	9 Stage setup	9 Stage setup
Opposite direction on revolution and rotation 0-2000rpm Same direction on revolution and rotation 0-1400rpm	10 Stage setup (But it can be restricted up to revolution speed)	10 Stage setup (But it can be restricted up to revolution speed)	10 Stage setup (But it can be restricted up to revolution speed)	10 Stage setup	10 Stage setup
Maximum 25 minutes (5 Step total, 1 step max is 900 seconds)	Maximum 25 minutes (5 step total)	Maximum 25 minutes (5 step total)	Maximum 25 minutes (5 Step total, 1 step max is 900 seconds)	Maximum 25 minutes (5 Step total, 1 step max is 900 seconds)	Maximum 25 minutes (5 Step total, 1 step max is 900 seconds)
5 Step 5 different kinds of motion pattern It can do continuous operation (on condition setup)	5 Step 5 different kinds of motion pattern It can do continuous operation (on condition setup)	5 Step 5 different kinds of motion pattern It can do continuous operation (on condition setup)	5 Step 5 different kinds of motion pattern It can do continuous operation (on condition setup)	5 Steps Enables to do continuous operation (condition setup) for three different kinds of movement	5 Steps Enables to do continuous operation (condition setup) for three different kinds of movement
90 CH 10 CH	90 CH 10 CH	90 CH 10 CH	90 CH 10 CH	User setup channels 90 CH Fixed channels 10 CH	90 CH 10 CH
Three Phase AC200-240VAC±10% 50/60Hz	Single Phase AC100-120VAC±10% Single Phase AC200-240VAC±10% 50/60Hz	Single Phase AC200-240VAC±10% 50/60Hz	Three phase AC200-240VAC±10% Three phase AC385-415VAC±10% 50/60Hz	Three phase AC200-240VAC±10% Three phase AC385-415VAC±10% 50/60Hz	Three phase AC200-240VAC±10% Three phase AC385-415VAC±10% 50/60Hz
2.0kW	1.5kw	2.0kW	3.0kW	2.5kW	2.5kW
W552xD650xH750 (mm)	W455xD540xH495 (mm) (Pump is separately provided)	W565xD682xH725 (mm) (Pump is separately provided)	W732xD820xH836 (mm) (Pump is separately provided)	W646xD663xH851 (mm)	W646xD663xH851 (mm)
About 120kg	About 80Kg (Pump is separately provided)	About 160Kg (Pump is separately provided)	About 260Kg (Pump is separately provided)	About 225kg	About 225kg

# Introduction Example

## Electronic, Information and Communication Electronics, Ceramics concerning manufacturer

### Mixing and degassing for high viscosity slurry (Alumina powder and thermoplastic resin)

Ceramics is widely used material which is excellent for wear resistance, heat resistance, corrosion resistance, vital compatibility and can be used from kitchenware to industrial use. However, they have high hardness and it take time to process with diamond tools grinding.

Therefore, ceramics products are practically expensive.

If mixing and melting ceramics powder with thermoplastic resin would enable to cast just like product configuration, it would be unnecessary to grind with diamond tools and eventually it can make at cheap cost due to less of process time.

However in this case, it might be causal for aggregation substance or crazing more from segregation spot. In other words, it would be very important to mix ceramics powder with resin uniformly. Then, we have tested various planetary motion mixers about capability comparison test.

At the result, our Kakuhunter is the best in terms of mixing and thermal control.

With respect to general machine which it only enables to setup

revolution due to fixed revolution-rotation revolving speed ratio, Kakuhunter enables to setup individually revolution and rotation speed, this would be the biggest advantage for us.

Besides, some machine which unable to control number of rotation can cause thermal elevation during mixing, then it can be caused problem about quality maintenance due to composition change from container melting or material vaporization.

Some machine has time lag between mixing and vacuum machine operation, then it can be intruded air into slurry, which can cause crack during cast, in addition, operation unable to continue because of drastic thermal elevation due to non control of number of rotation. On the other hands, In case of Kakuhunter, it enables to operate mixing and vacuum machine simultaneously, then enables to mix and degas under thermal control.

In this case, it could achieve good high viscosity slurry which we demand.

## Pharmaceutical Company

### Mixing and degassing for high density microplate in terms of active reaction test (High Throughput Screening)

In this drug development world, it would be very important to discover good physiological active substance at an early stage. To do this, it is essential to conduct active reaction test (High Throughput Screening: HTS) which match up hundreds of thousand of compound for short time such as one week against target disorder.

In order to conduct high reliable HTS, it would be necessary high accuracy molecule pipetting machine or analyze by using high density microplate such as 384 or 1536 Well (Hole) with high speed and sensitivity measurement device.

Microplate is getting higher density, more number of Well and smaller Well, under this circumstance, development of pipetting machine and measurement machine is following. Therefore we have considered HTS can conduct easily by using high density microplate.

However, in fact there are many tasks to overcome. Especially, it would be very tough to remove bubble of inside of Well due to reagent dispense and liquid mixing on each Well.

To introduce the Revolution-Rotation Motion Mixer & Degassing System, it enables to mix and degas for high density microplate which could not achieve mixing and degassing by using existing plate mixer or plate centrifuge.

Due to solution of problem, our machine is able to conduct high density microplate on various type of test and contribute quick accurate job of HTS.

# Academic-Industrial alliance, Research and Development

## Ritsumeikan University

Ritsumeikan University Science and engineering department,  
department of mechanical engineering professor, doctor of engineering Mr. Oogami Hirofumi

### Improvement research of mixing and degassing capability from academic-industrial alliance

At Ritsumeikan University, they are conducting contracted research basis by academic-industrial alliance, we are doing motional analysis of fluid or solid materials by using kaku-hunter, as well as proposal of improvement of this machine. In case of research field, we are doing motional fluid analysis by using computer and technological application and on this research, in following with materials physicality, We are adjusting parameter and doing motional analysis for fluid or solid materials inside of container during rotation by using computer which solve hydrokinetic motion equation. A few seconds immediate after mixing, it can occur drastic change, therefore we are especially analyzing well as important action process, but during mixing, it can be existing many parameters for interloping different physicality gas, liquid and solid, thus it would take huge time for calculation even a few seconds phenomenon. Based on analysis result, we are trying to make simulation video for an internal motion. Kaku-hunter could achieve that setup range of rotation ratio against revolution is wider, which in terms of

mixing and degassing under various circumstance logically and experimentally approved that is effective. Based on these experiences, we have tested several number of revolution-rotation ratio, rotation revolving speed or tilting angle of revolution axis as well as for several container shape. In this way, we have cooperated better and more effective mixing and degassing.

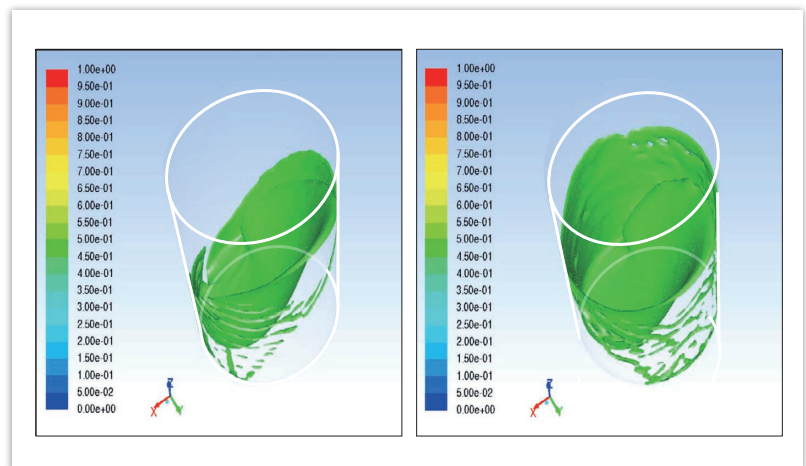

## Gifu University

### Prepared for ceramics slurry

Ceramic products are widely used considering the focus that has superior on high intensity, high tolerance, high wear resistance and thermal resistance. Besides, ceramics are focusing on not only structural material, but functional ceramic materials such as lead zirconium titanate or barium titanate for ferroelectric, as well. Ceramic casting have dry casting and wet casting methods. Regarding casting, slurry with powder material dispersed into solvent is arranging and then, with this solvent, molding is manufactured by various casting method. The Revolution-Rotation Motion Mixer & Degassing System "Kakuhunter" was used as purpose of this ceramic solvent mixing and it enables to mix just three minutes as good fluid solvent (concentrated slurry based solvent) which is coming near level that proceeded over half day by current ball milling method.

#### Tested mixing effect for planetary mixer with degassing function, Kakuhunter.

In order to test mixing effect, it would setup 7 as revolution speed, 9 as rotation speed, respectively, then on above picture, we describe result which measured viscosity of 81wt% density of Zirconium slurry by changing mixing time.

